

## Antes standard 24

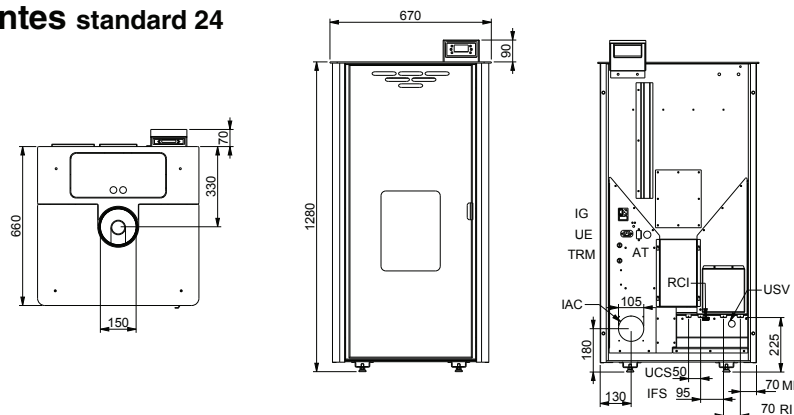

### Legenda

IG - interruttore generale - portafusibili  
 UE - uscita elettrovalvola  
 TRM - termostati a riarmo manuale  
 AT - termostato ambiente esterno  
 RCI - rubinetto carico impianto  
 IAC - ingresso aria comburente  
 UCS - uscita calda sanitaria 1/2" M  
 IFS - ingresso fredda sanitaria 1/2" M  
 RI - ritorno impianto 3/4" M  
 MI - mandata impianto 3/4" M  
 USV - uscita scarico valvole sicurezza



		24
Potenza termica nominale a pellet <i>Thermal nominal power with pellets</i>	kW	23,2
Potenza termica nominale a legna <i>Thermal nominal power with wood</i>	kW	16,9
Resa all'acqua a pellet / a legna <i>Water power with pellets / wood</i>	kW	20,3 / 10,8
Resa all'ambiente a pellet / a legna <i>Environmental power pellets / wood</i>	kW	2,9 / 6,0
Rendimento <i>Output</i>	%	82
Consumo orario [pellet / legna] <i>Hourly consumption [pellet / wood]</i>	Kg/h	[2,5 - 6] / [1 - 6]
Dimensione canna fumaria <i>Dimension of chimney</i>	Ø cm	15
Dimensioni camera di combustione pellet <i>Dimensions combustion chamber pellet</i>	cm	40 x 35 x 30 h
Dimensioni camera di combustione legna <i>Dimensions combustion chamber wood</i>	cm	40 x 35 x 26 h
Capacità serbatoio pellet <i>Capacity of pellet tank</i>	Kg	35
Peso <i>Weight</i>	Kg	-260

\*optional



Bianco White  
 Amaranto Amaranth  
 Samoa Samoa  
 Ciliegio Cherry  
 Noce Walnut

I colori e le finiture qui riportati devono ritenersi puramente indicativi. - Colours and finishes shown here are merely indicative.

## Antes country 24

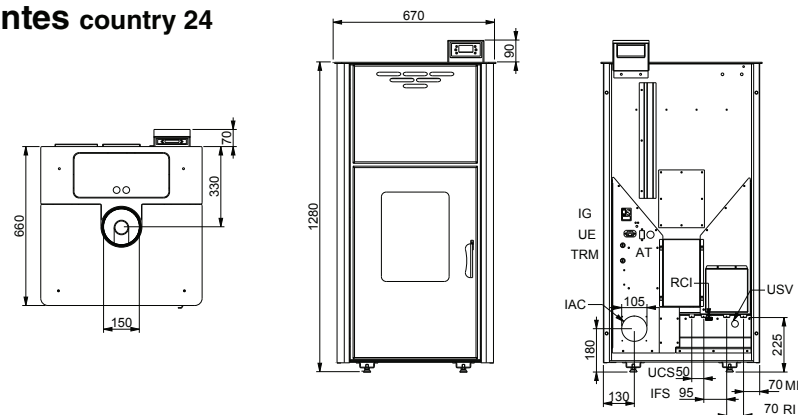

### Legenda

IG - interruttore generale - portafusibili  
 UE - uscita elettrovalvola  
 TRM - termostati a riarmo manuale  
 AT - termostato ambiente esterno  
 RCI - rubinetto carico impianto  
 IAC - ingresso aria comburente  
 UCS - uscita calda sanitaria 1/2" M  
 IFS - ingresso fredda sanitaria 1/2" M  
 RI - ritorno impianto 3/4" M  
 MI - mandata impianto 3/4" M  
 USV - uscita scarico valvole sicurezza



		24
Potenza termica nominale a pellet <i>Thermal nominal power with pellets</i>	kW	23,2
Potenza termica nominale a legna <i>Thermal nominal power with wood</i>	kW	16,9
Resa all'acqua a pellet / a legna <i>Water power with pellets / wood</i>	kW	20,3 / 10,8
Resa all'ambiente a pellet / a legna <i>Environmental power pellets / wood</i>	kW	2,9 / 6,0
Rendimento <i>Output</i>	%	82
Consumo orario [pellet / legna] <i>Hourly consumption [pellet / wood]</i>	Kg/h	[2,5 - 6] / [1 - 6]
Dimensione canna fumaria <i>Dimension of chimney</i>	Ø cm	15
Dimensioni camera di combustione pellet <i>Dimensions combustion chamber pellet</i>	cm	40 x 35 x 30 h
Dimensioni camera di combustione legna <i>Dimensions combustion chamber wood</i>	cm	40 x 35 x 26 h
Capacità serbatoio pellet <i>Capacity of pellet tank</i>	Kg	35
Peso <i>Weight</i>	Kg	-260

\*optional



Bianco White  
 Amaranto Amaranth  
 Samoa Samoa  
 Ciliegio Cherry  
 Noce Walnut

I colori e le finiture qui riportati devono ritenersi puramente indicativi. - Colours and finishes shown here are merely indicative.

## Antes modular 24

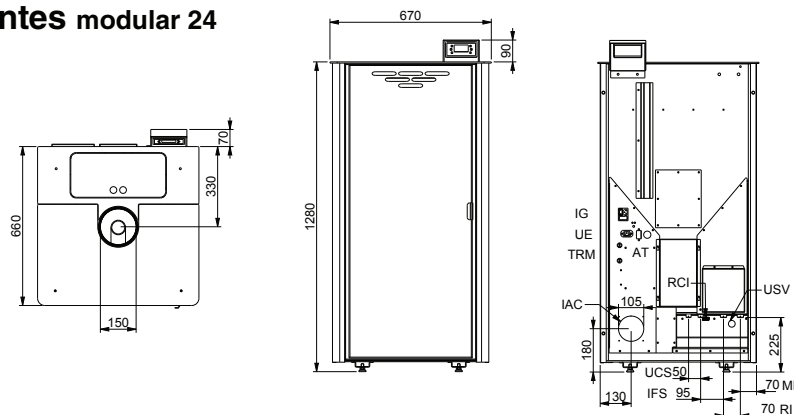

### Legenda

IG - interruttore generale - portafusibili  
 UE - uscita elettrovalvola  
 TRM - termostati a riarmo manuale  
 AT - termostato ambiente esterno  
 RCI - rubinetto carico impianto  
 IAC - ingresso aria comburente  
 UCS - uscita calda sanitaria 1/2" M  
 IFS - ingresso fredda sanitaria 1/2" M  
 RI - ritorno impianto 3/4" M  
 MI - mandata impianto 3/4" M  
 USV - uscita scarico valvole sicurezza



		24
Potenza termica nominale a pellet <i>Thermal nominal power with pellets</i>	kW	23,2
Potenza termica nominale a legna <i>Thermal nominal power with wood</i>	kW	16,9
Resa all'acqua a pellet / a legna <i>Water power with pellets / wood</i>	kW	20,3 / 10,8
Resa all'ambiente a pellet / a legna <i>Environmental power pellets / wood</i>	kW	2,9 / 6,0
Rendimento <i>Output</i>	%	82
Consumo orario [pellet / legna] <i>Hourly consumption [pellet / wood]</i>	Kg/h	[2,5 - 6] / [1 - 6]
Dimensione canna fumaria <i>Dimension of chimney</i>	Ø cm	15
Dimensioni camera di combustione pellet <i>Dimensions combustion chamber pellet</i>	cm	40 x 35 x 30 h
Dimensioni camera di combustione legna <i>Dimensions combustion chamber wood</i>	cm	40 x 35 x 26 h
Capacità serbatoio pellet <i>Capacity of pellet tank</i>	Kg	35
Peso <i>Weight</i>	Kg	-260

\*optional



Bianco  
White

Amaranto  
Amaranth

Samoa  
Samoa

Ciliegio  
Cherry

Noce  
Walnut

I colori e le finiture qui riportati devono ritenersi puramente indicativi. - Colours and finishes shown here are merely indicative.

## Antes exclusive 24

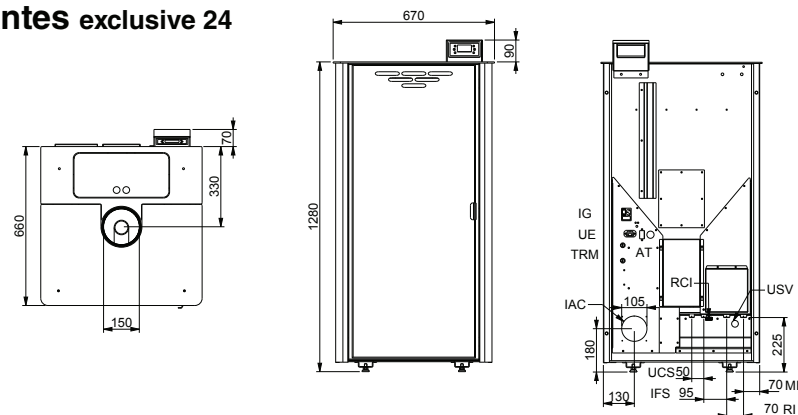

### Legenda

IG - interruttore generale - portafusibili  
 UE - uscita elettrovalvola  
 TRM - termostati a riarmo manuale  
 AT - termostato ambiente esterno  
 RCI - rubinetto carico impianto  
 IAC - ingresso aria comburente  
 UCS - uscita calda sanitaria 1/2" M  
 IFS - ingresso fredda sanitaria 1/2" M  
 RI - ritorno impianto 3/4" M  
 MI - mandata impianto 3/4" M  
 USV - uscita scarico valvole sicurezza



### Legenda

IG - igeneral switch - fuse holder  
 UE - solenoid valve output  
 TRM - manual reset thermostats  
 AT - external room thermostat  
 RCI - faucet loading system  
 IAC - combustion air inlet  
 UCS - 1/2" M domestic hot water outlet  
 IFS - sanitary cold inlet 1/2" M  
 RI - return of the 3/4" M system  
 MI - 3/4" M system delivery  
 USV - safety valve exhaust outlet

		24
Potenza termica nominale a pellet <i>Thermal nominal power with pellets</i>	kW	23,2
Potenza termica nominale a legna <i>Thermal nominal power with wood</i>	kW	16,9
Resa all'acqua a pellet / a legna <i>Water power with pellets / wood</i>	kW	20,3 / 10,8
Resa all'ambiente a pellet / a legna <i>Environmental power pellets / wood</i>	kW	2,9 / 6,0
Rendimento <i>Output</i>	%	82
Consumo orario [pellet / legna] <i>Hourly consumption [pellet / wood]</i>	Kg/h	[2,5 - 6] / [1 - 6]
Dimensione canna fumaria <i>Dimension of chimney</i>	Ø cm	15
Dimensioni camera di combustione pellet <i>Dimensions combustion chamber pellet</i>	cm	40 x 35 x 30 h
Dimensioni camera di combustione legna <i>Dimensions combustion chamber wood</i>	cm	40 x 35 x 26 h
Capacità serbatoio pellet <i>Capacity of pellet tank</i>	Kg	35
Peso <i>Weight</i>	Kg	-260

\*optional



Nero / Specchio  
Black / Mirror

I colori e le finiture qui riportati devono ritenersi puramente indicativi. - Colours and finishes shown here are merely indicative.

## Ecate quadra standard / modular 17

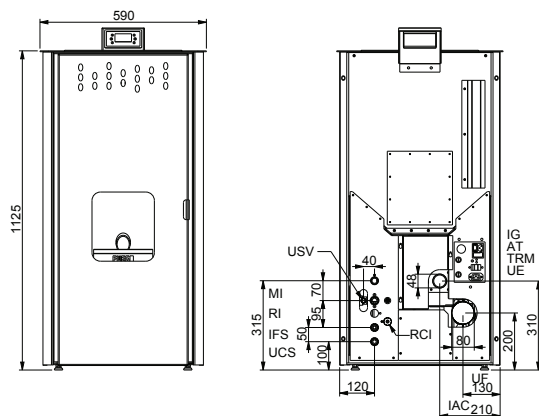
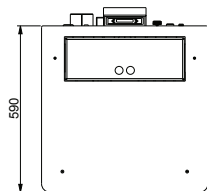

### Legenda

IG - interruttore generale  
 AT - termostato ambiente esterno  
 TRM - termostati a riarmo manuale  
 UE - uscita elettrovalvola  
 UF - uscita fumi  
 IAC - ingresso aria comburente  
 MI - mandata impianto 3/4" M  
 RI - ritorno impianto 3/4" M  
 IFS - ingresso fredda sanitaria 1/2" M  
 UCS - uscita calda sanitaria 1/2" M  
 RCI - rubinetto carico impianto  
 USV - uscita scarico valvole sicurezza

### Legenda

IG - switch  
 AT - external room thermostat  
 TRM - manual reset thermostats  
 UE - solenoid valve output  
 UF - smoke outlet  
 IAC - combustion air inlet  
 MI - 3/4" M system delivery  
 RI - return of the 3/4" M system  
 IFS - sanitary cold inlet 1/2" M  
 UCS - 1/2" M domestic hot water outlet  
 RCI - faucet loading system  
 USV - safety valve exhaust outlet

Icona	Modello	17
	Potenza termica nominale <i>Thermal nominal power</i>	kW 16,74
	Resa all'acqua <i>Water power</i>	kW 12,76
	Resa all'ambiente <i>Environmental power</i>	kW 3,98
	Rendimento <i>Output</i>	% 87,39
	Consumo orario pellet <i>Hourly consumption pellet</i>	Kg/h 3,89
	Temperatura media fumi <i>Average smoke temperature</i>	°C 144
	Tiraggio canna fumaria <i>Sucking of chimney</i>	Pa 11
	Capacità serbatoio pellet <i>Capacity of pellet tank</i>	Kg -30
	Peso <i>Weight</i>	Kg 195

\*optional



Bianco  
White

Amaranto  
Amaranth

Samoa  
Samoa

Ciliegio  
Cherry

Noce  
Walnut

I colori e le finiture qui riportati devono ritenersi puramente indicativi. - Colours and finishes shown here are merely indicative.

## Ecate quadra country 17

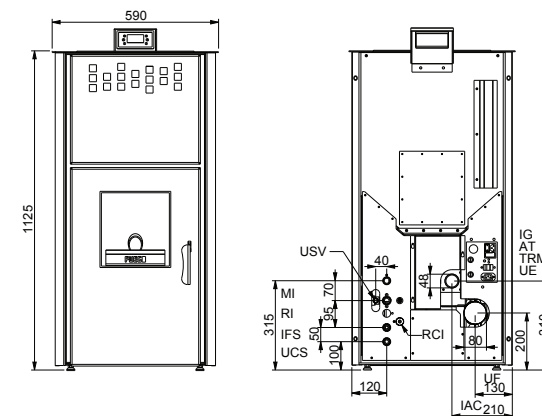
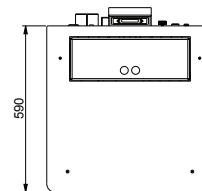

### Legenda

IG - interruttore generale  
 AT - termostato ambiente esterno  
 TRM - termostati a riarmo manuale  
 UE - uscita elettrovalvola  
 UF - uscita fumi  
 IAC - ingresso aria comburente  
 MI - mandata impianto 3/4" M  
 RI - ritorno impianto 3/4" M  
 IFS - ingresso fredda sanitaria 1/2" M  
 UCS - uscita calda sanitaria 1/2" M  
 RCI - rubinetto carico impianto  
 USV - uscita scarico valvole sicurezza

### Legenda

IG - switch  
 AT - external room thermostat  
 TRM - manual reset thermostats  
 UE - solenoid valve output  
 UF - smoke outlet  
 IAC - combustion air inlet  
 MI - 3/4" M system delivery  
 RI - return of the 3/4" M system  
 IFS - sanitary cold inlet 1/2" M  
 UCS - 1/2" M domestic hot water outlet  
 RCI - faucet loading system  
 USV - safety valve exhaust outlet

Icona	Modello	17
	Potenza termica nominale <i>Thermal nominal power</i>	kW 16,74
	Resa all'acqua <i>Water power</i>	kW 12,76
	Resa all'ambiente <i>Environmental power</i>	kW 3,98
	Rendimento <i>Output</i>	% 87,39
	Consumo orario pellet <i>Hourly consumption pellet</i>	Kg/h 3,89
	Temperatura media fumi <i>Average smoke temperature</i>	°C 144
	Tiraggio canna fumaria <i>Sucking of chimney</i>	Pa 11
	Capacità serbatoio pellet <i>Capacity of pellet tank</i>	Kg -30
	Peso <i>Weight</i>	Kg 195

\*optional



Bianco  
White

Amaranto  
Amaranth

Samoa  
Samoa

Ciliegio  
Cherry

Noce  
Walnut

I colori e le finiture qui riportati devono ritenersi puramente indicativi. - Colours and finishes shown here are merely indicative.

## Ecate tonda standard / modular 17

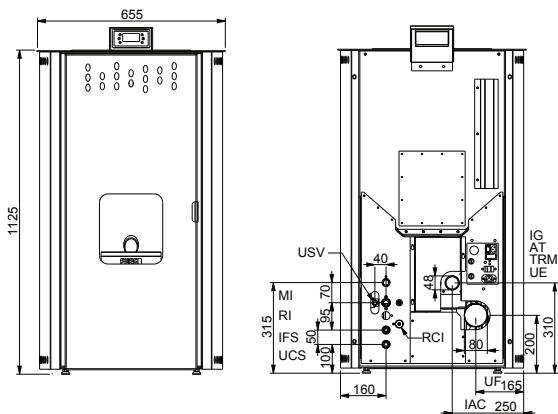
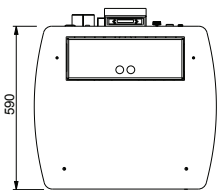

### Legenda

IG - interruttore generale  
 AT - termostato ambiente esterno  
 TRM - termostati a riarmo manuale  
 UE - uscita elettrovalvola  
 UF - uscita fumi  
 IAC - ingresso aria comburente  
 MI - mandata impianto 3/4" M  
 RI - ritorno impianto 3/4" M  
 IFS - ingresso fredda sanitaria 1/2" M  
 UCS - uscita calda sanitaria 1/2" M  
 RCI - rubinetto carico impianto  
 USV - uscita scarico valvole sicurezza

### Legenda

IG - switch  
 AT - external room thermostat  
 TRM - manual reset thermostats  
 UE - solenoid valve output  
 UF - smoke outlet  
 IAC - combustion air inlet  
 MI - 3/4" M system delivery  
 RI - return of the 3/4" M system  
 IFS - sanitary cold inlet 1/2" M  
 UCS - 1/2" M domestic hot water outlet  
 RCI - faucet loading system  
 USV - safety valve exhaust outlet

		17
	Potenza termica nominale <i>Thermal nominal power</i>	kW 16,74
	Resa all'acqua <i>Water power</i>	kW 12,76
	Resa all'ambiente <i>Environmental power</i>	kW 3,98
	Rendimento <i>Output</i>	% 87,39
	Consumo orario pellet <i>Hourly consumption pellet</i>	Kg/h 3,89
	Temperatura media fumi <i>Average smoke temperature</i>	°C 144
	Tiraggio canna fumaria <i>Sucking of chimney</i>	Pa 11
	Capacità serbatoio pellet <i>Capacity of pellet tank</i>	Kg -30
	Peso <i>Weight</i>	Kg 195

\*optional



Bianco  
White

Amaranto  
Amaranth

Samoa  
Samoa

Ciliegio  
Cherry

Noce  
Walnut

I colori e le finiture qui riportati devono ritenersi puramente indicativi. - Colours and finishes shown here are merely indicative.

## Ecate tonda country 17

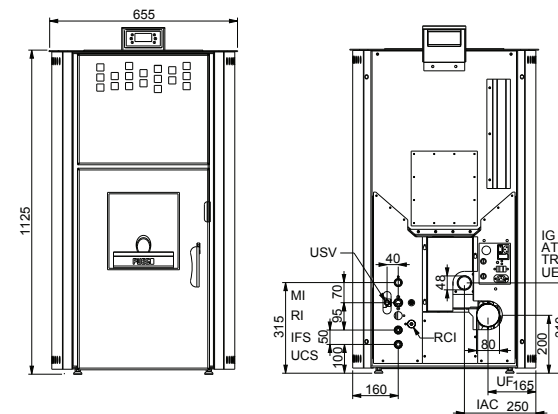
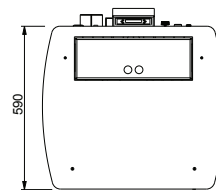

### Legenda

IG - interruttore generale  
 AT - termostato ambiente esterno  
 TRM - termostati a riarmo manuale  
 UE - uscita elettrovalvola  
 UF - uscita fumi  
 IAC - ingresso aria comburente  
 MI - mandata impianto 3/4" M  
 RI - ritorno impianto 3/4" M  
 IFS - ingresso fredda sanitaria 1/2" M  
 UCS - uscita calda sanitaria 1/2" M  
 RCI - rubinetto carico impianto  
 USV - uscita scarico valvole sicurezza

### Legenda

IG - switch  
 AT - external room thermostat  
 TRM - manual reset thermostats  
 UE - solenoid valve output  
 UF - smoke outlet  
 IAC - combustion air inlet  
 MI - 3/4" M system delivery  
 RI - return of the 3/4" M system  
 IFS - sanitary cold inlet 1/2" M  
 UCS - 1/2" M domestic hot water outlet  
 RCI - faucet loading system  
 USV - safety valve exhaust outlet

		17
	Potenza termica nominale <i>Thermal nominal power</i>	kW 16,74
	Resa all'acqua <i>Water power</i>	kW 12,76
	Resa all'ambiente <i>Environmental power</i>	kW 3,98
	Rendimento <i>Output</i>	% 87,39
	Consumo orario pellet <i>Hourly consumption pellet</i>	Kg/h 3,89
	Temperatura media fumi <i>Average smoke temperature</i>	°C 144
	Tiraggio canna fumaria <i>Sucking of chimney</i>	Pa 11
	Capacità serbatoio pellet <i>Capacity of pellet tank</i>	Kg -30
	Peso <i>Weight</i>	Kg 195

\*optional



Bianco  
White

Amaranto  
Amaranth

Samoa  
Samoa

Ciliegio  
Cherry

Noce  
Walnut

I colori e le finiture qui riportati devono ritenersi puramente indicativi. - Colours and finishes shown here are merely indicative.